

1 **BOTTOM STACK PROFILE**
SCALE 2 : 1

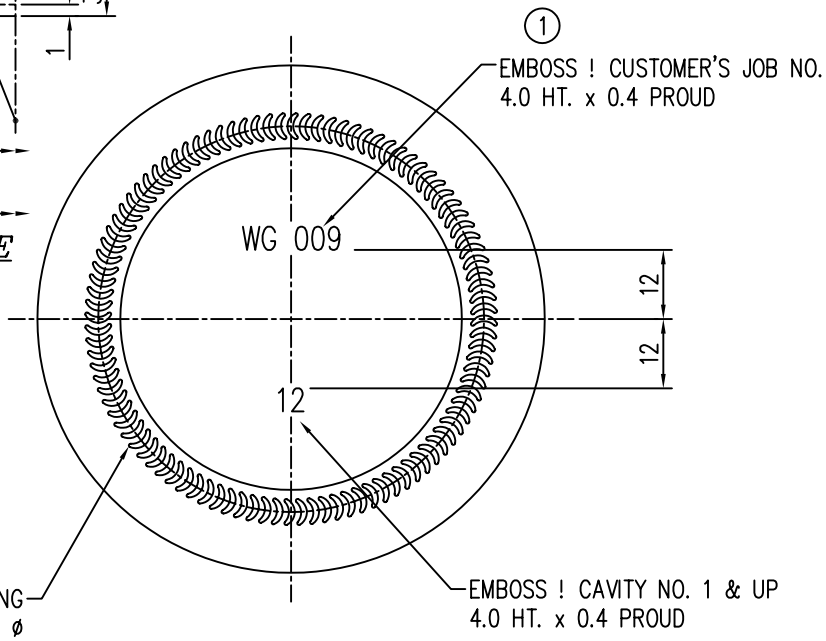

REVISION		
NO.	DATE	REMARKS
1.	26.03.07	- REVISED AS SHOWN.

J.C.L. ENGINEERING PTE. LTD.
APPROVAL PRINT
26 MAR 2007
SIGNATURE :

CUSTOMER	WADI GLASS
ITEM	660ml JAR
FINISH TYPE	GPI 82-2040
WEIGHT	280gm ± 5 gm
FILL PT. CAP.	DATE 08.03.07
BRIMFUL CAP.	660ml ± 4 ml
NOM. HEADSPACE	CHK'D
DES'D BY ESTHER	DRG NO. 660 JAR/WD-1